



Renegade

RAIDER



T LEHMAN
TRIKES

Leader of the Three World®

LEHMAN TRIKES

Beginning with a Dream...

In 1985, John Lehman completed the first Lehman Trike. His vision was to provide a safe and comfortable motorcycle for his family to enjoy the riding experience together. Using his garage as a workshop, and a 1981 Honda CB900, he had successfully achieved his goal. At the time, John could never have imagined he was establishing the foundation for a new era of modern-day trikes.

As people learned of the trike John had created, word spread and soon it became apparent that there was emerging interest for three-wheel motorcycles. The stage was set, and a company dedicated to providing an entirely new three-wheel experience was born.

The Original Trike Company...

Lehman Trikes has become the premier name in three-wheel motorcycles. Originally founded and established in the quiet rural community of Westlock, Alberta, Canada, Lehman has grown to become provider of choice for Original Equipment Manufacturers, supported by a team of dedicated employees, dealers and industry partners.

Based in Spearfish, South Dakota, Lehman Trikes are proudly made in the USA and feature our three year, unlimited mileage

warranty. Factory and dealer support for our products has earned Lehman an exceptional reputation. Lehman Trikes is proud to have established the kind of customer relationships and loyalty that can only be earned through years of dedication and integrity.

Committed to the Three Wheel Experience...

Lehman Trikes has achieved recognition throughout the motorcycle community for innovation, leadership and the advancement of three-wheel motorcycles. Our dedication to industry leadership and customer satisfaction is what sets Lehman apart. All Lehman Trikes are assembled by Factory Trained Technicians and are supported by the most highly qualified network of Authorized Lehman Dealers. Our commitment to safety, quality and performance assures confidence and control around every corner.

For over 25 years, Lehman has been an industry leader and earned the reputation for high quality, premium trikes. "Leader of the Three World" represents our commitment to the three-wheel motorcycle experience.

In 2012 Lehman was acquired by Champion Investments, Inc. and became a member of the Champion family of motorcycle-related companies.



John Lehman, Founder

August 4, 1951 - January 5, 2012

2009 Sturgis Motorcycle Museum & Hall of Fame Inductee

RAIDER

for Sportster®

Experience a

Designed to grip the road through every
delivers optimal stability and control.
back roads, experience the



TRUNK

Convenient and lockable. Perfect
for your camera and a jacket!

SPORTSTER® RAIDER SPECS

Mfr. ModelSportster®
Wheel Base61 in. (1549 mm)
Overall Length97 in. (2464 mm)
Overall Width54 in. (1372 mm)
Curb Weight.....833 lbs. (378 kg)
Trunk Volume.....2 cu.ft. (57 L)

All Models and/or dimensions may not be
exactly as shown and are subject to change.



Genuine Lehman!

corner, Lehman's original "No-Lean" Suspension
On the freeway and down your favorite
Freedom of a Genuine Lehman.

Renegade

for Dyna®



LUGGAGE RACK

Polished stainless steel rack
secures extra luggage.

PASSENGER BACKREST

Sturdy chromed steel Sissy Bar with
Back Rest provides comfort for your
passenger. Includes mounting
hardware. *Not for use with Tour Pack.

DYNA® RENEGADE SPECS

Mfr. Model.....	Dyna®
Wheel Base.....	68.5 in. (1740 mm)
Overall Length.....	107 in. (2718 mm)
Overall Width.....	53 in. (1346 mm)
Curb Weight.....	1003 lbs. (455 kg)
Trunk Volume.....	5 cu.ft. (142 L)

All Models and/or dimensions may not be
exactly as shown and are subject to change.

Renegade

for Road King®

Style and Cr

Superior to traditional fiberglass technology, Re
process to ensure consistent thickness and smoo
delivers unmatched strength and durability combine



TRUNK

Large opening for easy access and with 5 cu.ft. of storage space, there is plenty of room for your gear, including full-face helmets.

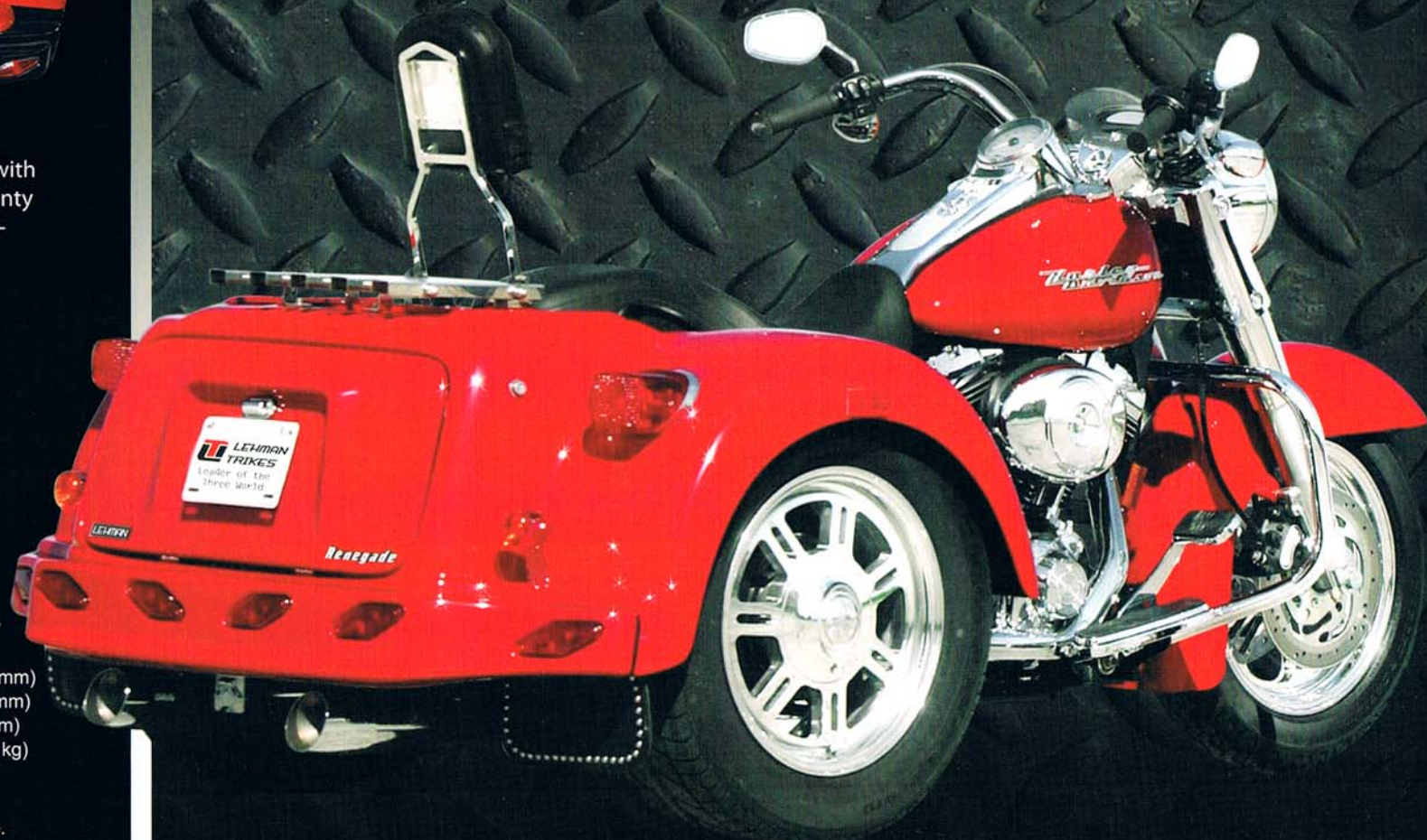

ROAD KING® RENEGADE SPECS

Mfr. Model	Road King®
Wheel Base	64.5 in. (1638 mm)
Overall Length	102 in. (2591 mm)
Overall Width	53 in. (1346 mm)
Curb Weight	1069 lbs. (485 kg)
Trunk Volume	5 cu.ft. (142 L)

All Models and/or dimensions may not be exactly as shown and are subject to change.

craftsmanship

Resin Transfer Molding (RTM) utilizes a closed mold on surfaces inside and out. The Lehman Renegade is built with the finest in fit and finish quality for your ride!

Renegade

for Softail®



LIGHT BAR

Dress up your trike & enhance visibility. Features six dual filament lights offering both driving and braking illumination.

SOFTAIL® RENEGADE SPECS

Mfr. Model	Softail®
Wheel Base	65.5 in. (1664 mm)
Overall Length	106 in. (2692 mm)
Overall Width	53 in. (1346 mm)
Curb Weight.....	1023 lbs. (464 kg)
Trunk Volume.....	5 cu.ft. (142 L)

All Models and/or dimensions may not be exactly as shown and are subject to change.

Renegade

for Touring

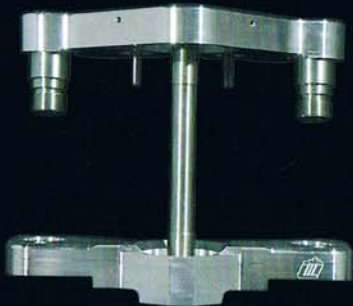

ACME TRIPLE TREE

Give your Electra Glide trike "power steering". Adds rake over the stock motorcycle.



ACME REVERSE 5 & 6-SPEED

Optional reverse gear for your Renegade. Operated with the shift lever for ease of use. Developed by Champion Trikes.



Be Daring. Be Different. Be a Renegade.

Stand out from the crowd with a Lehman Renegade. This touring machine commands attention everywhere it goes and its striking design is the perfect platform for creating your own one-of-a-kind three-wheel experience. The ultimate touring trike, uniquely crafted for each individual rider.



HAWG EFX

Complete the look of the ultimate touring trike with color matched EFX. Diverts debris and rain away from your legs.

FLHT® RENEGADE SPECS

Mfr. Model	FLHT®
Wheel Base	63.5 in. (1613 mm)
Overall Length	103 in. (2616 mm)
Overall Width	53 in. (1346 mm)
Curb Weight.....	1141 lbs. (455 kg)
Trunk Volume.....	5 cu.ft. (142 L)

All Models and/or dimensions may not be exactly as shown and are subject to change.

Genuine

“NO-LEAN” SUSPENSION

NO-LEAN DESIGN

“No-Lean” is the original Lehman philosophy for uncompromised trike stability. Lehman’s proprietary design virtually eliminates chassis flex throughout the vehicle. This provides the foundation for superior handling performance and a precise, controlled ride. A trike, unlike an automobile, does not have two wheels in front to assist with stability. The trike chassis design is therefore essential in maintaining complete three-wheel stability.

NO-LEAN PERFORMANCE

Cornering stability and steering control are maximized by the genuine “No-Lean” design. All three wheels remain firmly intact with the road while cornering. Undesirable flex in the chassis and suspension would cause the trike to sway and lean outward as it is maneuvered, shifting the center of gravity to the outside of the turn resulting in decreased stability and heavier steering. Every Lehman trike is specifically designed and precision crafted for the ultimate “No-Lean” experience.

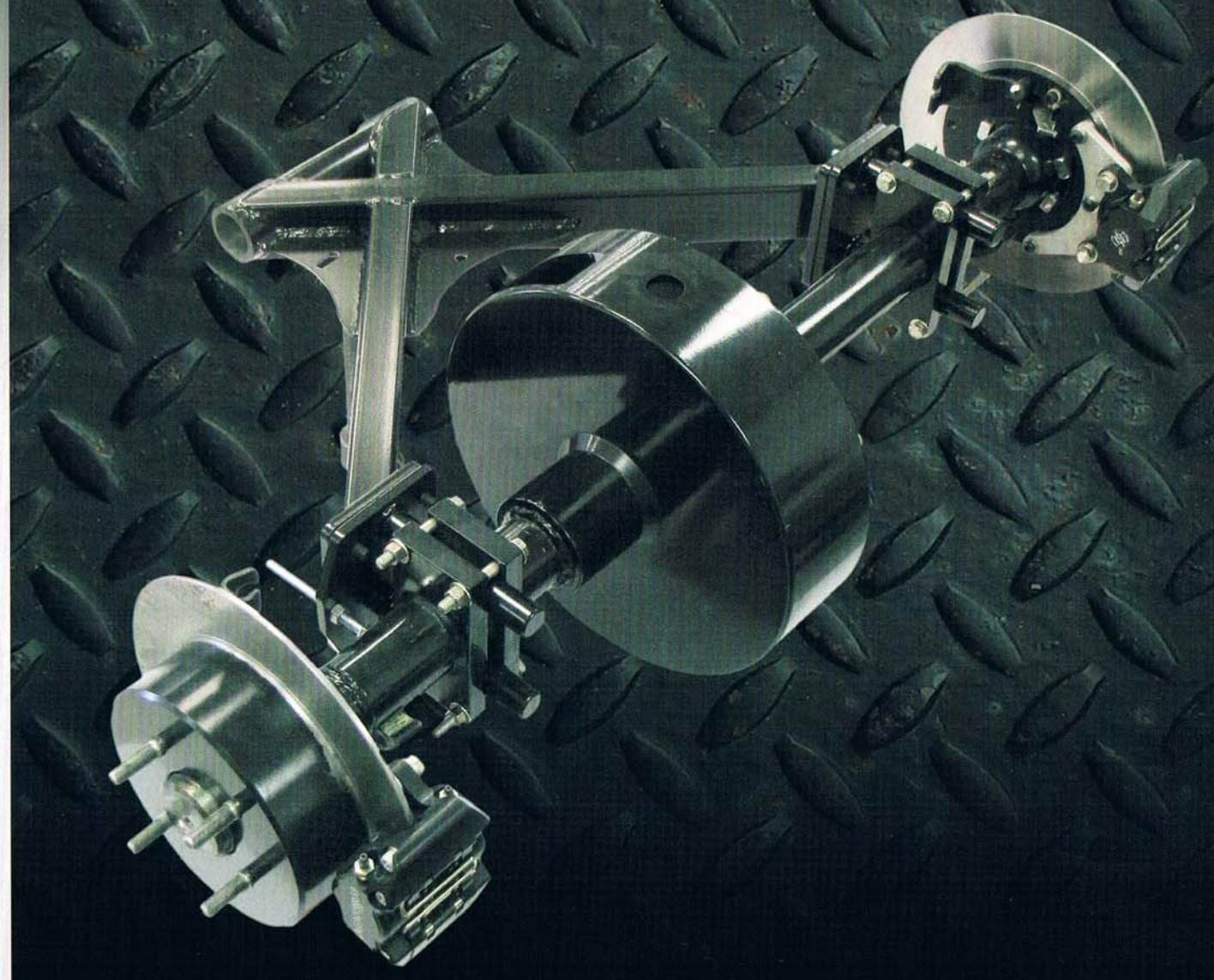

LEHMAN PRIDE



There is a unique camaraderie among Lehman Trike riders, an exclusive experience that only other Lehman owners can truly understand and appreciate. Riding down a narrow winding road or riding into the horizon on the highway, you are filled with Pride.

Lehman Pride is the original factory sponsored trike owners group created to share a common bond; our passion for three wheel motorcycles. Lehman Pride kicked off in 2000 with the inaugural Pride Ride where customers and Lehman staff rode over 10,000 miles, crossing 26 states and 2 provinces. This marked the beginning of many journeys and lifelong relationships forged between a company and its customers.

Lehman Pride is about meeting new friends and feeling as if you've known each other for a lifetime. It's the experiences at small town burger bars, the laughs at roadside breaks, and relaxing together after a long day of riding.

Pride Matters is the exclusive magazine for Pride Members. Read about Lehman Trikes and your fellow Lehman riders and their travels. Share your Pride and open road adventures as we take part in your three wheel motorcycle journey, wherever the road may lead...





Leader of the Three World®

125 Industrial Drive, Spearfish, SD 57783

Toll Free: 1-888-3WHEELS • Fax: 1-605-642-1184

www.lehmantrikes.com • sales@lehmantrikes.com

Champion Investments, Inc., a privately held company, dba Lehman Trikes USA



TRIKE ZONE

Corner of Hwy 616 & 780
Mulhurst, AB (Pigeon Lake)

P: 780-389-3344 www.TrikeZone.com

F: 780-389-3318 sales@TrikeZone.com

All Models and/or dimensions may not be exactly as shown and are subject to change.
Harley-Davidson® products offered by Lehman Trikes are not licensed or endorsed by Harley-Davidson®
Printed in USA